

You've come a long way...  
Shouldn't your presentation?



*Make the Best Impression*



GRAPHIC DESIGN • PROMOTIONAL ITEMS • ROLL-UP BANNERS • BANNER STANDS  
POP-UP DISPLAYS • TABLE TOPS • TABLE COVERS • BROCHURE DISPLAYS  
PORTABLE DEMO CENTERS • ACCESSORIES



**Nema Associates, Inc.**  
 408 East Elizabeth Ave., Linden, NJ 07036  
 P 908.275.3840 • F 908.525.3987  
 www.nemadesign.com

You and your company have come along way since your first presentation

# BRING YOUR PRESENTATION UP TO DATE

We offer a complete line of high quality, easy-to-use, and affordable portable display products for trade shows, point of purchase, marketing, advertising, events, presentations and displays. Our portable display products are designed with one thing in mind—to allow you to effectively and conveniently brand your products and services. In addition to our full spectrum of **Graphic Design** and **Printing** services, we are all about solutions

## CONTENTS

<b>POP-UP DISPLAY SYSTEMS</b>	04-09
<hr/>	
<b>POP-UP EXPRESS</b>	10
<hr/>	
<b>TOWER DISPLAYS</b>	10
<hr/>	
<b>TOPPERS TABLETOP DISPLAYS</b>	11
<hr/>	
<b>FABRIC PANEL SYSTEMS</b>	12
<hr/>	
<b>LAMINATE PANEL SYSTEMS</b>	13
<hr/>	
<b>ALUMALITE HYBRID DISPLAYS</b>	
<hr/>	
Alumalite Classic .....	18
Alumalite Lineare .....	19
Alumalite Zero .....	19
Alumalite Kiosks .....	19
<hr/>	
<b>ACCESSORIES</b>	
<hr/>	
Lighting & Shelves .....	18
Literature Racks .....	19
<hr/>	
<b>ULTRAFORM PORTABLE COUNTERS</b>	20-21
<hr/>	
<b>CASES</b>	22-23
<hr/>	
<b>FLOORING PACKAGES</b>	24-25
<hr/>	
<b>COLOR OPTIONS</b>	26
<hr/>	
<b>BANNER STANDS</b>	27-31
<hr/>	
<b>PROMOTOR</b>	32-33
<hr/>	
<b>ADDITIONAL SERVICES</b>	34-35
<hr/>	



## FEATURED PRODUCTS



### DELUXE ROLL-UP BANNER STAND

Our most popular bannerstand. Supreme has all the features you need to make your display or event a success.

- Comes complete with sleek metal base, replaceable cartridge, telescopic pole and carrying case.
- Replaceable cartridge allows quick and easy banner changes
- Optional banner light

### POP-UP DISPLAYS

Pop-up displays set up quickly and easily, and are perfect for making a good impression on a budget. Choose from 8ft and 10ft pop-ups featuring straight, curved or wave profiles, or explore our 20ft display with gullwing, serpentine, curve-straight, or straight-curve-straight footprints. All are available with wheeled shipping cases that transform into a counter at the show; other accessories include lights, shelves, monitor mounts and more.



### PROMO DEMO CENTER

Promo Demo Center is a light weight portable demonstration promotional and in-store sampling counter designed for easy transportation. Polypropylene is the material used for the body panel incorporating unique "hinges" for easy folding.

This re-usable easy to assemble display counter is available in black or white.

### ALUMALITE

The First Family of Alumatite Display Systems!

The Alumatite consists of three products lines: CLASSIC, LINEARE and ZERO, our most affordable entry level linear system. All are lightweight, pack compactly in a foam fitted wheeled cases, and reduced your shipping, drayage and set up costs. Most 10' units can be set up by two people in less than ninety minutes. Available in 10' and 20' inline configurations.





## FABRIC / GRAPHIC



Fabric pop-up displays set up quickly and easily, and are perfect for making a good impression on a budget. All of our pop-ups are made in the USA and come with a limited lifetime frame warranty. These display packages come with everything you need: a sturdy display frame, panels in your choice of 54 FRONTRUNNER or PRELUDE fabric colors, a rugged, lightweight rotomolded case, and UL approved, halogen or Las Vegas light kits. Podium conversion kits, shelves, backlit headers and LED lighting are some of the available options.

**\*Economy Packages (PL)** offer curved profiles, and are available in both floor-standing and tabletop models. Economy frames are constructed from 8mm aircraft aluminum frame, and come with a limited lifetime warranty.

Our **Premium Packages (PRC)** offer a sturdier frame constructed of 8mm and 13mm aircraft aluminum. These floor standing models are available in a variety of shapes and sizes, including curved, straight and wave.

Fabric panels are included but graphic panels can be added to any of the packages below. Please refer to page 9 to see our packages that come pre-configured with graphic panels.

## 8' CURVED

Packages includes aircraft aluminum frame, QuickStart instructions and all items listed below.

Plan View	Product #	Panels	Lights* (150w Halogen)	Case	Size (inches)	Approx. weight (pounds)	Shipping Size	Ships ( ) Boxes
	PL-4	5	2	4400	96 x 94.4	76	38.5 x 26 x 15	(1)
	PL-5	5	2	4600	96 x 94.4	78	37.5 x 26.5 x 18	(1)
	PL-13	5	2	4400	94.5 x 93	65	38.5 x 26 x 15	(1)
	PRC-5	5	2	4600	98.5 x 88	80	37.5 x 26.5 x 18	(1)
	PRC-6	5	2	(2) 4200 A (2) 4200 B	98.5 x 88	123	A: 39.625 x 20.675 x 13.5 B: 39.625 x 20.375 x 17.625	(2)

## 10' CURVED

Packages includes aircraft aluminum frame, QuickStart Instructions and all items listed below.

Plan View	Product #	Panels	Lights* (150w Halogen)	Case	Size (inches)	Approx. weight (pounds)	Shipping Size	Ships ( ) Boxes
	PL-2	6	2	4400	118.8 x 94.4	85	38.5 x 26 x 15	(1)
	PL-3	6	2	4600	118 x 94.4	87	38 x 26.5 x 16	(1)
	PL-12	6	2	(2) 4200 A (2) 4200 B	118.8 x 94.4	159	A: 39.625 x 20.675 x 13.5 B: 39.625 x 20.375 x 17.625	(2)
	PRC-1	6	2	4600	117 x 88	88	37.5 x 26.5 x 18	(1)
	PRC-4	6	2	(2) 4200 A (2) 4200 B	117 x 88	134	A: 39.625 x 20.675 x 13.5 B: 39.625 x 20.375 x 17.625	(1)

\*Available incandescent Las Vegas Lights, LED lighting options.



(shown with optional monitor/mount and 4600 case conversion kit).



(shown with optional header, 4200 A/B case conversion kit).



(shown with optional 4200 A/B case conversion kit).

## 10' STRAIGHT

Package includes aircraft aluminum frame, Quickstart instructions, and all items listed below.

Plan View	Product #	Panels	Lights* (150w Halogen)	Case	Size (inches)	Approx. weight (pounds)	Shipping Size	Ships ( ) Boxes
	PRS-1	6	2	4600	117 x 88	100	37.5 x 26.5 x 18	(1)
	PRS-2	6	2	(1) 4200 A (1) 4200 B	117 x 88	135	A: 39.625 x 20.675 x 13.5 B: 39.625 x 20.375 x 17.625	(2)
	PRS-8	9	2	(2) 4600	112 x 88	151	37.5 x 26.5 x 18	(2)
	PRS-9	9	2	(1) 4200 A (2) 4200 B	112 x 88	182	A: 39.625 x 20.675 x 13.5 B: 39.625 x 20.375 x 17.625	(3)

## 10' WAVE

Package includes aircraft aluminum frame, QuickStart Instructions and all items listed below.

Plan View	Product #	Panels	Lights* (150w Halogen)	Case	Size (inches)	Approx. weight (pounds)	Shipping Size	Ships ( ) Boxes
	PRC-13	6	2	4600	117 x 88	88	37.5 x 26.5 x 18	(1)
	PRC-14	6	2	(1) 4200 A (1) 4200 B	117 x 88	130	A: 39.625 x 20.675 x 13.5 B: 39.625 x 20.375 x 17.625	(2)

## TABLE TOP POP-UPS

We offer a wide variety of tabletop displays for smaller shows and presentations. Enjoy the convenience of a lightweight, portable display at your next meeting or event. Our pop-up and folding tabletop displays are among the most economical and durable on the market today.

Packages include Self-Locking Frame, QuickStart Instructions and all items listed below.

Plan View	Product #	Panels	Lights* (150w Halogen)	Case	Size (inches)	Approx. weight (pounds)	Shipping Size	Ships ( ) Boxes
	PL-6 (8ft)	5	2	4106	95 x 59.5	46	35 x 16 x 17	(1)
	PL-7 (6ft)	4	1	4106	69.6 x 59.5	41	35 x 16 x 17	(1)

\*Available incandescent Las Vegas Lights, LED lighting options.



shown with optional graphics

*Your Design & Advertising agency... we are all about solutions!*



PRC8 (shown with optional graphics and 4200 A/B case conversion kits)



PRS14 (shown with 4600 case conversion kits)

## 20' GULLWING

Package includes aircraft aluminum frame, QuickStart Instructions and all items listed below.

Plan View	Product #	Panels	Lights* (150w Halogen)	Case	Case (conversion kit)	Size (inches)	Approx. weight (pounds)	Shipping Size	Ships ( ) Boxes
	PL-8	11	4	(2) 4400	2	235.6 x 94.4	175	38.5 x 26 x 15	(2)
	PL-9	11	4	(2) 4600	2	235.6 x 94.4	172	37.5 x 27.5 x 18	(2)
	PRC-7	11	4	(2) 4600	2	231 x 88	173	37.5 x 20 x 18	(2)
	PRC-8	11	4	(2) 4200 A (2) 4200 B	4	231 x 88	251	A: 39.625 x 20.675 x 13.5 B: 39.625 x 20.375 x 17.625	(4)

## 20' STRAIGHT

Package includes aircraft aluminum frame, QuickStart Instructions and all items listed below.

Plan View	Product #	Panels	Lights* (150w Halogen)	Case	Case (conversion kit)	Size (inches)	Approx. weight (pounds)	Shipping Size	Ships ( ) Boxes
	PRS-11	13	4	(3) 4600	2	234 x 88	213	37.5 x 26.5 x 18	(3)
	PRS-12	13	4	(2) 4200 A (2) 4200 B	2	234 x 88	274	A: 39.625 x 20.675 x 13.5 B: 39.625 x 20.375 x 17.625	(4)
	PRS-14	12	4	(3) 4600	2	234 x 88	213	37.5 x 26.5 x 18	(3)
	PRS-15	12	4	(3) 4200 A (3) 4200 B	2	234 x 88	360	A: 39.625 x 20.675 x 13.5 B: 39.625 x 20.375 x 17.625	(6)

\*Available incandescent Las Vegas Lights, LED lighting options.



PRC-19 (shown with optional graphics and 4200 A/B case conversion kits)



PRC-11 (shown with optional graphics and 4200 A/B case conversion kits)

## 20' SERPENTINE

Package includes aircraft aluminum frame, fabric panels, QuickStart Instructions and all items listed below.

Plan View	Product #	Panels	Lights* (150w Halogen)	Case	Case (Conversion Kit)	Size (inches)	Approx. weight (pounds)	Shipping Size	Ships ( ) Boxes
	PRC-10	10	4	(2) 4600	2	217 x 88	172	37.5 x 26.5 x 18	(2)
	PRC-11	10	4	(2) 4200 A (2) 4200 B	2	217 x 88	246	A: 39.625 x 20.675 x 13.5 B: 39.625 x 20.375 x 17.625	(4)

## 20' CURVE-STRAIGHT

Package includes aircraft aluminum frame, QuickStart Instructions and all items listed below.

Plan View	Product #	Panels	Lights* (150w Halogen)	Case	Case (Conversion Kit)	Size (inches)	Approx. weight (pounds)	Shipping Size	Ships ( ) Boxes
	PRC-16	10	4	(2) 4600	2	234 x 88	173	37.5 x 26.5 x 18	(2)
	PRC-17	10	4	(2) 4200 A (2) 4200 B	2	234 x 88	247	A: 39.625 x 20.675 x 13.5 B: 39.625 x 20.375 x 17.625	(4)

## 20' STRAIGHT-CURVE-STRAIGHT

Package includes aircraft aluminum frame, QuickStart Instructions and all items listed below.

Plan View	Product #	Panels	Lights* (150w Halogen)	Case	Case (Conversion Kit)	Size (inches)	Approx. weight (pounds)	Shipping Size	Ships ( ) Boxes
	PRC-19	10	4	(2) 4600	2	234 x 88	173	38 x 27.5 x 16	(2)
	PL-5	10	4	(2) 4200 A (2) 4200 B	2	234 x 88	247	A: 39.625 x 20.675 x 13.5 B: 39.625 x 20.375 x 17.625	(4)

\*Available incandescent Las Vegas Light, LED lighting options.

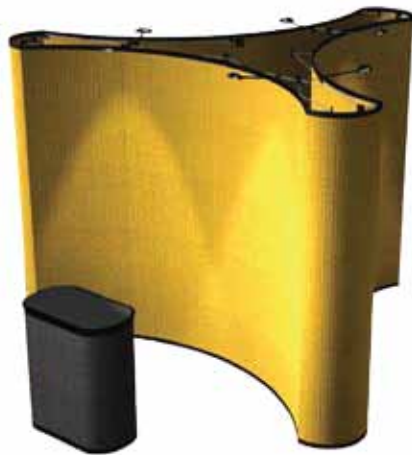

(shown with halogen lights and 4600 case conversion kits)



## ISLAND

Package includes aircraft aluminum frame, QuickStart Instructions and all items listed below.

Product #	Panels	Lights* (150w Halogen)	Case	Case (Conversion Kit)	Size (inches)	Approx. weight (pounds)	Shipping Size	Ships ( ) Boxes
PL-16	15	6	(3) 4600	3	139 x 93	275	37.5 x 26.5 x 18	(3)

### 4600 case top option



4600

### 4600 ALL-IN-ONE CASE

This durable rotomolded case provides the ultimate protection for fabric and graphic panels, keeping your exhibit safe and clean show after show. Outfitted with integrated wheels and handle, the 4600 provides the ultimate ease of handling and portability for your exhibit, saving on transportation costs. Convert your 4600 case to a podium with our graphic or fabric wrap options and a selection of hinged wood tops that pack inside the case with our Economy Pop-up packages (will not fit inside case with Premium frames).

## CASE CONVERSION OPTIONS

Below are some of the available case options for our Pop-up packages.



4400



4400 w/ optional lyca wrap and top kit



4600 (with optional fabric wrap)



4600 w/ optional wood top & graphic wrap



4200 A/B (with optional fabric wrap)

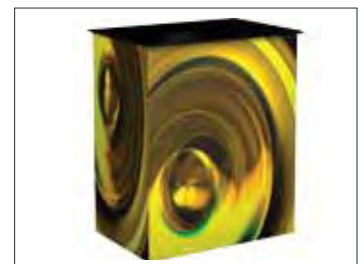

4200 A/B w/ optional graphic wrap

\*Available incandescent Las Vega Lights, LED lighting options.





(shown with optional 4600 graphic case conversion kit and Las Vegas Lights.)



## 10' CURVE

Package includes aircraft aluminum frame, QuickStart Instructions and all items listed below.

Plan View	Product #	Panels	Lights* (150w Halogen)	Case	Case (Conversion Kit)	Size (inches)	Approx. weight (pounds)	Shipping Size	Ships ( ) Boxes
	PL3-G4	(4) graphic (2) fabric	2	4600	1	118.8 x 94.4	95	38 x 27.5 x 16	(1)
	PL3-G6	(6) graphic		4600	1	118.8 x 94.4	5	38 x 27.5 x 16	(1)
	PL12-G4	(4) graphic (2) fabric	2	4200 A 4200 B	1	118.8 x 94.4	159	A: 39.625 x 20.675 x 13.5 B: 39.625 x 20.375 x 17.625	(2)
	PL12-G6	(6) graphic	2	4200 A 4200 B	1	118.8 x 94.4	159	A: 39.625 x 20.675 x 13.5 B: 39.625 x 20.375 x 17.625	(2)



(shown with 4600 case conversion)

## GRAPHIC POP-UP DISPLAY PACKAGES

Customize your pop-up display with high-quality mural graphic panels. We print all of our graphics panels in house on state-of-the-art HP printers, and then assemble every unit for quality control before it ships. You can be assured that everything fits perfectly because we know that the last thing you need to worry about on the exhibit show floor is your exhibit.

## ISLAND GRAPHIC PACKAGE

Package includes aircraft aluminum frame, QuickStart Instructions and all items listed below.

Product #	Front Panels	End Panels	Lights* (150w Halogen)	Case	Case Conversion Kit	Size (inches)	Approx. weight (pounds)	Shipping Size	Ships ( ) Boxes
PL16-G4	(12) graphic	(3) fabric	6	(3) 4600	3	139 x 93	275	37.5 x 26.5 x 18	(3)
PL16-G6	(12) graphic	(3) graphic	6	(3) 4600	3	139 x 93	275	37.5 x 26.5 x 18	(3)

\*Available incandescent Las Vegas Lights, LED lighting options.

*Your Design & Advertising agency... we are all about solutions!*



PRS-21 - (shown with optional end caps)

## POP-UP EXPRESS

Pop-Up Express offers the simplicity of a traditional pop-up with the convenience of a pre-attached, seamless, dye-sublimated tension fabric graphic. Simply expand the frame into position and show! Pop-Up Express displays are available in four sizes, and come complete with a sturdy aluminum frame, full sized dye-sublimated stretch fabric graphic and a wheeled rotomolded case. Optional end caps, lighting kits, and case upgrades are available.

Package includes aircraft aluminum frame, dye-Sub fabric graphic print, QuickStart Instructions and all items listed below.

Plan View	Product #	Case	Size (inches)	Shipping Size	Ships ( ) Boxes
	PRS-24	4100	59.5 x 59.5	19 x 13 x 38	(1)
	PRS-26	4100	88 x 59.5	19 x 13 x 38	(1)
	PRS-19	4100	88 x 88	19 x 13 x 38	(1)
	PRS-21	4100	117 x 88	19 x 13 x 38	(1)



PRS18-BLT (left)  
PRS 18 (right) shown with optional halogen lights

## TOWER DISPLAYS

Our tower displays are a sleek addition to any exhibit space. Constructed of 8mm drawn aluminum, each tower comes with a limited Lifetime Warranty on the frame and is easily transported in its heavy-duty rotomolded case. Select from fabric, graphic, or back-lit graphic options.

Packages Include Frame, Channel Bars, Frame Bag, Channel Bar Bag, QuickStart Instructions and all items listed below.

Product #	Description	Case	Size (inches)	Approx. weight (pounds)	Shipping Size	Ships ( ) Boxes	Ships ( ) Boxes
PRS18	3 fabric panels	4400	25.5 x 91.5	58	38.5 x 26 x 15	(1)	(1)
PRS18-BLT	3 back-lit poly-film graphic mural panels and back-lit package	4400	25.5 x 91.5	60	38.5 x 26 x 15	(1)	(1)
PRS18-FLT	3 poly-film graphic mural panels and front-lit package	4400	25.5 x 91.5	59	38.5 x 26 x 15	(1)	(1)

## TOPPERS

### Big display impact in a very small space...

Toppers broadcast your message in a big way. These ultramodern tabletop systems are built of aircraft grade aluminum, and feature a large footprint for stability. Each Toppers display comes complete with the frame, graphics, headers and wings, lights and a wheeled rotomolded case. Toppers set-up and break down in minutes, and everything packs neatly inside the foam-fitted rotomolded wheeled case. Toppers are made in the USA, and are backed by a limited lifetime frame warranty.



#### Packing System

Every Toppers display comes complete with a rotomolded, wheeled case for easy transportation. Each part of your Toppers has a unique location within the custom foam fitted case, to make finding each part a snap. The lightweight, heavy-duty case will protect your Topper while reducing shipping and handling weight. Toppers cases can be shipped FedEx or UPS, or checked in as airline luggage.



PLTT-1

## TOPPERS

All Toppers packages include Octanorm Frame, Center Graphic, Header and Wing graphics, (2) 150 watt Halogen Lights, 5PCC-02 case and QuickStart Instructions.

Product #	Size (Inches)	Lights (150w Halogen)	Approx. weight (pounds)	Shipping Size	Ships ( ) Boxes
PLTT-X	67 x 52	2	68	48 x 28 x 9 -13	(1)

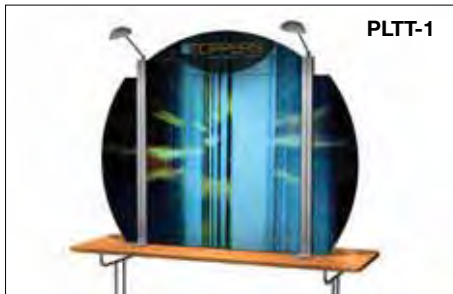

PLTT-1

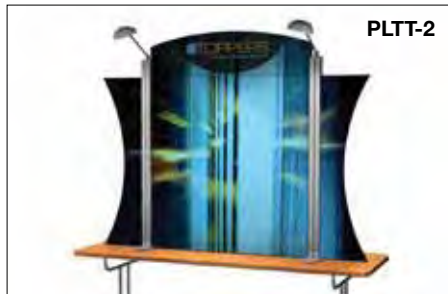

PLTT-2

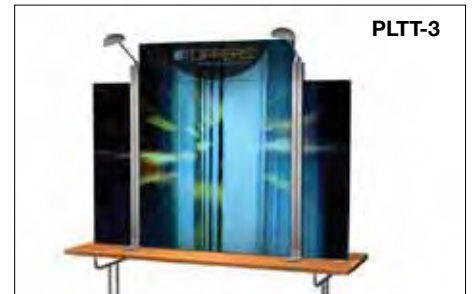

PLTT-3

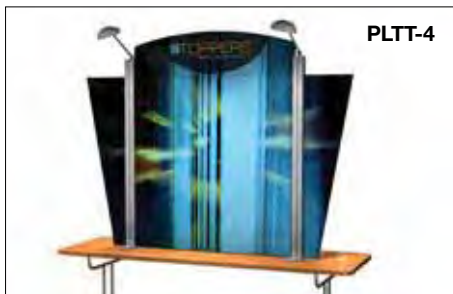

PLTT-4

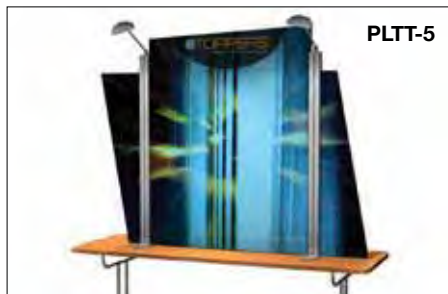

PLTT-5

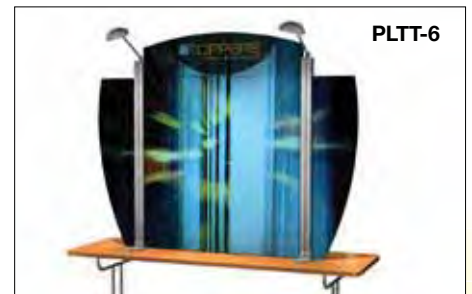

PLTT-6

## OPTIONAL LAMINATE COLORS

Toppers come standard with a silver aluminum frame. Satin black or Satin white powder-coated or laminate colors are available for an additional charge.

## TOPPERS ALUMINUM FRAME COLORS

STANDARD



Silver

OPTIONAL POWDER COAT



Satin White

Satin Black

## OPTIONAL LAMINATE FRAME COLORS



Mahogany

Amber Maple

*Your Design & Advertising agency... we are all about solutions!*



PLP-3  
(shown with optional monitor/mounts, graphics & UltraForm counter ULO2037 which can be purchase separately)



PLP-9  
(shown with optional monitor kits, graphics & UltraForm counter ULO2037 purchase separately)



5PCC-02

## MULTICONNECT FABRIC PANEL SYSTEMS

Multiconnect is engineered to take anything the most grueling trade show schedule can dish out. Hardwood frames covered in your choice of FRONTRUNNER™ or PRELUDE™ fabric provide maximum durability while the patented hinged panels let you create unique custom shapes for dramatic trade show booth effects that are easy to set up and reconfigure. Multiconnect lets you add bridges, towers and backlit headers that are sure to get you noticed on the trade show floor. A huge selection of trade show booth accessories are available to tailor your trade show exhibit to meet your unique marketing needs including lightboxes, product display cases and monitor kits.

### 10' SYSTEMS

Package Includes, QuickStart Instructions and all items listed below.

Plan View	Product #	Case	Includes	Size (inches)	Approx. weight (pounds)	Shipping Size	Ships ( ) Boxes
	PLP-1	(2) 5PCC-02	Backwall	112.8 x 94.4	127.7	48 x 28 x 9 -13	(2)
	PLP-3	(3) 5PCC-02	Backwall, plex header (1), alcove counter (1)	112.8 x 94.4	194.5	48 x 28 x 9 -13	(3)
	PLP-5	(4) 5PCC-02	Backwall, plex header (1), alcove counter (1) peninsula counter(1)	112.8 x 94.4	256	48 x 28 x 9 -13	(4)

### 20' SYSTEMS

Package Includes, QuickStart Instructions and all items listed below.

Plan View	Product #	Case	Includes	Size (inches)	Approx. weight (pounds)	Shipping Size	Ships ( ) Boxes
	PLP-9	(4) 5PCC-02	Backwall, (2) backlit header & lights	237.6 x 92.4	255.5	48 x 28 x 9 -13	(4)
	PLP-10	(5) 5PCC-02	Backwall, alcove counter (2) plex header (2)	237.6 x 92.4	389.2	48 x 28 x 9 -13	(5)
	PLP-12	(7) 5PCC-02	Backwall, plex header (2), alcove counter (2) peninsula counter(2)	231.6 x 94.4	620	48 x 28 x 9 -13	(7)



PLL-12  
(shown with optional monitors/mounts and stand off plex)

## LAMINATE PANEL SYSTEMS

Encompassing an unparalleled selection of components, features and accessories, our laminate panel systems meld precision engineering with the highest quality materials. Select from our 12 standard laminates a look as unique as you are. Laminate systems are available in both 10x10 and 10x20 configurations, and offer a variety of options in product display counters, alcoves, storage and headers. Options include lightbox graphics and slatwall for product merchandising. All of our panel systems come complete with rugged, lightweight shipping cases that stand up to any grueling exhibit schedule while reducing shipping weight.

## 10' SYSTEMS

Package Includes, QuickStart Instructions and all items listed below.

Plan View	Product #	Case	Includes	Size (inches)	Approx. weight (pounds)	Shipping Size	Ships ( ) Boxes
	PLL-1	(2) 5PCC-02	Backwall	120 x 91 x 24.25D	182	48 x 28 x 9 -13 (telescoping)	(2)
	PLL-3	(3) 5PCC-02	Backwall, plex header (1), alcove counter base with hinged door (1)	120 x 91 x 24.25D	260	48 x 28 x 9 -13 (telescoping)	(3)
	PLL-5	(4) 5PCC-02	Backwall, plex header (1), alcove counter (1) radius peninsula counter top and base (1)	113 x 91 x 60D	326	48 x 28 x 9 -13 (telescoping)	(4)

## 20' SYSTEMS

Package Includes, QuickStart Instructions and all items listed below.

Plan View	Product #	Case	Includes	Size (inches)	Approx. weight (pounds)	Shipping Size	Ships ( ) Boxes
	PLL-9	*5PCC-05	Backwall, plex header (2), alcove (2), radius peninsula counter top & base	240 x 91 x 24.25D	452	52 x 26.5 x 11.5	(2)
	PLL-10	*5PCC-05	Backwall, alcove counter (2) plex header (2)	240 x 91 x 24.25D	556	52 x 26.5 x 11.5	(2)
	PLL-12	*5PCC-05	Backwall, alcove counter (2) plex header (2) peninsula counter (2)	240 x 91 x 60D	559	52 x 26.5 x 11.5	(2)

\*4 5PCC-05 cases may be substituted for transport tub at no extra charge.

*Your Design & Advertising agency... we are all about solutions!*



AL2 - monitor not included

## ALUMALITE CLASSIC

Alumalite is the portable modular display system that raises your brand image while lowering your shipping and install/dismantle costs. An entire 10' Alumalite system can be assembled quickly and easily, and weighs less than 200 lbs. with cases. An incredible 81" wide by 84" high central graphics area blocks the view of whatever is behind you. Graphics are available in your choice of either dye sublimation printed tension fabric or roll on graphic mural. Choose from three available canopy shapes: Wave, Arch or Straight, in dozens of colors at no additional charge. Wings are available in frosted plex, standard laminates or sintra. The optional counter is available as an attached or free-standing unit, and features room for a computer workstation, removable shelving and lockable storage. Rental packages available!



ALUMALITE  
10x10 (AL1)



ALUMALITE  
10x10 (AL3)



## 10' ALUMALITE CLASSIC

Packages Include Backwall Octanorm Hardware, Canopy, Fabric Canopy Cover, Frosted Plex Header & Wings and QuickStart Instructions.

Product #	Canopy	Case	Size (inches)	Approx. weight (pounds)	Shipping Size	Ships ( ) Boxes
AL1	Wave	(2) 5PCC-02	96 x 117 x 23	154	48 x 28 x 9 -13	(2)
AL2	Arch	(2) 5PCC-02	96 x 117 x 23	154	48 x 28 x 9 -13	(2)
AL3	Straight	(2) 5PCC-02	96 x 117 x 23	154	48 x 28 x 9 -13	(2)



ALUMALITE 10x20 (AL4)



ALUMALITE 10x20 (AL5)



ALUMALITE 10x20 (AL6)

## 20' ALUMALITE CLASSIC

Packages Include Backwall Octanorm Hardware, Canopy, 2" Aluminum Tubing, Fabric Canopy Cover, Frosted Plex Header & Wings and QuickStart Instructions.

Product #	Canopy	Case	Size (inches)	Approx. weight (pounds)	Shipping Size	Ships ( ) Boxes
AL4	Wave	(4) 5PCC-02	96 x 239 x 23	308	48 x 28 x 9 -13	(4)
AL5	Arch	(4) 5PCC-02	96 x 239 x 23	308	48 x 28 x 9 -13	(4)
AL6	Straight	(4) 5PCC-02	96 x 239 x 23	308	48 x 28 x 9 -13	(4)

Images shown with optional lights, shelves, counters, graphics, monitor kits. PLEASE NOTE: All specifications provided do not include counters. Alumalite Classic and Alumalite Linear counters pack and ship separately. Alumalite Zero counters pack together with base unit - up to 2 counters can fit in one same case.



AL7

## NEW! ALUMALITE LINEARE

- Large scale graphic panels and return walls to create a bold, unforgettable statement.
- Adjustable, illuminated header with graphics for dramatic effects,
- Lightweight frame is sturdy enough to support up to 40" monitors!
- Generous array of options and add-ons: free standing and fixed lockable counters, lights, shelves, monitor mount kits, and literature racks
- Lightweight and sturdy stackable cases for low shipping costs and space efficient storage



(shown with optional slatwall, counters and monitor kits)

## 10' ALUMALITE LINEARE

Packages include backwall hardware, illuminated header, side headers and return walls and QuickStart instructions.

Product #	Canopy Header	Case	Size (inches)	Approx. weight (pounds)	Shipping Size	Ships ( ) Boxes
AL7	Illuminated Header	(2) UF4831-AL	96 x 117 x 34.25	247	48 x 31 x 6-10	(2)



AL8

## 20' ALUMALITE LINEARE

Packages include, illuminated header, side headers and return walls and QuickStart Instructions.

Product #	Canopy Header	Case	Size (inches)	Approx. weight (pounds)	Ships ( ) Boxes
AL8	Illuminated Header	(3) UF4831-AL	96 x 239 x 34.25	425	4

Images shown with optional lights, shelves, counters, graphics, monitor kits. PLEASE NOTE: All specifications provided do not include counters pack and ship separately. AluMAlite Zero counters pack together with base unit - up to 2 counters can fit in one same case.

*Your Design & Advertising agency... we are all about solutions!*

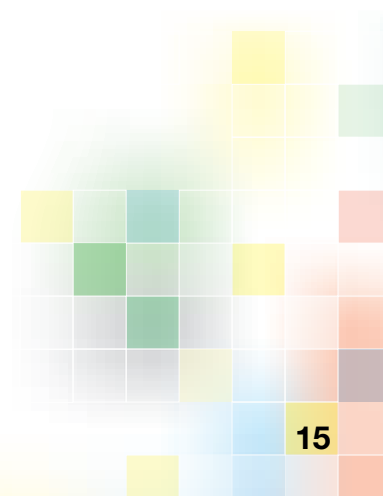



### ALUMALITE ZERO

The lowest cost, most advanced budget hybrid system on the market

- Durable Octanorm frame
- Frosted Plex, Graphics ready sintra, or sintra with graphic wings, headers and front counter panel
- Entire Alupalite ZERO unit with backwall graphics and up to two counters packs in **one wheeled transport case**
- New easy to adjust magnet to steel graphics mounting system
- Alupalite ZERO unit with one counter weighs only 133 pounds

AZ1:  
(shown with optional counter, shelves, monitor kits & graphics.)



AZ2                      AZ3                      AZ4                      AZ5                      AZ6                      AZ7                      AZ8

### 10' ALUMALITE ZERO

Packages include Octanorm hardware, frosted plex header and wings, Quickstart instructions and wheeled case and Frosted Plex Header & Wings,

Product #	Header	Case	Size (inches)	Approx. weight (pounds)	Shipping Size	Ships ( ) Boxes
AZ1-8	Illuminated Header	5PCC-02	96 x 117 x 34.25	133	48 x 28 x 9 - 13	(1)



AZ9 - (shown with optional counters, monitor kits and shelves)

### 20' ALUMALITE ZERO

Packages include backwall hardware, frosted plex headers and wings, wheeled shipping cases.

Product #	Header	Case	Size (inches)	Approx. weight (pounds)	Shipping Size	Ships ( ) Boxes
AZ9	Illuminated Header	(2) 5PCC-02	96 x 239 x 23	274	48 x 28 x 9 - 13 (with up to 2 counters)	(2)

Images shown with optional lights, shelves, counters, graphics, monitor kits. PLEASE NOTE: All specifications provided do not include counters. Alupalite Classic and Alupalite Linear counters pack and ship separately. Alupalite Zero counters pack together with base unit - up to 2 counters can fit in one same case.





ALK-1 -shown with optional monitor kits, keyboard shelf (keyboard not included)



ALK-2

## ALUMALITE KIOSKS

Perfect for information centers at trade shows, events, and company lobbies and facilities, Alumatite kiosks can be configured for Audio/ Video, slatwall or shelving for product displays, or graphics for branding, advertising and promotional messages.

Complete Plug and Play packages are available including pre-wiring and all electronics.

Alumatite portable modular kiosks pack down in foam-fitted, wheeled, molded transport cases for easy shipping and handling and can be set up by one person in less than an hour. They are available for sale or rental in a wide range of standard laminates or specialty laminates to match any look or color.

Kiosk Packages Includes:

- Octanorm Frame
- Locking Storage Cabinet
- Illuminated Header
- Header Graphics
- Back wall graphics

Optional monitor kit & literature rack available.



## ALUMALITE KIOSKS

Product #	Header	Case	Size (inches)	Approx. weight (pounds)	Shipping Size	Ships ( ) Boxes
ALK-1	Illuminated Header	5PCC-02	92 x 26 x 24	103	48 x 28 x 13	(1)
ALK-2	Illuminated Header	5PCC-02	92 x 26 x 24	139	48 x 28 x 13	(1)

## ALUMALITE FRAME COLORS

STANDARD	OPTIONAL POWDER COAT	
silver	satin black	satin white

## COUNTER / HEADER / WING LAMINATE OPTIONS

amber maple	mahogany	platinum	black	white	PREMIUM brushed aluminum
-------------	----------	----------	-------	-------	-----------------------------

## ALUMALITE CANOPY COLORS (EXPRESS)

coal	snow	silver
------	------	--------

## ALUMALITE CUSTOM CANOPY COLORS (SAME PRICE; 1 WEEK ADDITIONAL LEAD TIME)

aqua	avocado	cadet blue	celadon	chocolate	coral	dove gray	fiery red	ginger	indigo	kelly	lime green
magenta	nutmeg	pashmina	periwinkle	pumpkin	rosemary	royal	seafoam	slate blue	tangerine	titanium	yellow

*Your Design & Advertising agency... we are all about solutions!*



LED



Las Vegas Light (75w)  
Las Vegas approved  
(required for Las Vegas Convention Center)



Economy 150w Halogen Light



Premium 150w Halogen Light



10301 Basic Shelf (black)



10303 Premium Shelf (black)



Banner light



Monitor mount up to 23"



Monitor mount 23" to 40"

LIGHTING / SHELVES / MONITOR MOUNTS

Product #	Description	Size (inches)	Approx. weight (pounds)	Shipping Size	Ships ( ) Boxes
2005-04-250	75w Las Vegas Light incandescent (sold in sets of five)	4 x 14	1	4 x 14	(1)
2001-04	Premium 150w halogen (2 per set)	8 x 18	2	8 x 18	(1)
2001-U	Economy 150w halogen	8 x 18	2	8 x 18	(1)
AL-MON-01	Monitor mount 19 to 23	4.5 x 4.5	5	8 x 6 x 6	(1)
AL-MON-03	Monitor mount 23 to 40	11.25 x 14	11	14 x 14 x 6	(1)
10301	Basic shelf package: 3 single metal shelves, 6 brackets and nylon bag.	5.5 x 30	6	36 x 6 x 6	(1)
10303	Premium shelf package: 4 single shelves, 8 brackets, 2 double brackets, 5.5" x 30" 8 32" x 8" x 8" 2 literature brackets literature strip and nylon bag.	5.5 x 30	8	36 x 6 x 6	(1)
PLBNR-LIGHT-01	Bannerstand light	3 x 3 x 17	1	4 x 4 x 18	(1)



## STACY LITERATURE RACK

Product #	Description	Size (inches)	Approx. weight (pounds)	Shipping Size	Ships ( ) Boxes
ET-2060	STACY: collapsible flat pack design, steel and aluminum frame, 2X- sided display and aluminum case.	10" x 50.5"	19	18" x 13" x 6"	(1)



## COMET LITERATURE RACK

Product #	Description	Size (inches)	Approx. weight (pounds)	Shipping Size	Ships ( ) Boxes
ET-2061	COMET: collapsible flat pack design, 4 clear A4 portrait style pockets, chromed steel frame and base with nylon carrying case	10" x 61"	14	12" x 12" x 19"	(1)



## BROCHURE NET (4 AND 8 POCKET)

Product #	Description	Size (inches)	Approx. weight (pounds)	Shipping Size	Ships ( ) Boxes
ET-2071	BROCHURE NET 8-pocket: Flat-pack design, steel and aluminum frame, fabric mesh pockets and nylon carrying case.	20" x 54"	7	24" x 6" x 6"	(1)
ET-2070	BROCHURE NET 4-pocket: Flat-pack design, steel and aluminum frame, fabric mesh pockets and nylon carrying case.	10.5" x 54"	5	24" x 6" x 6"	(1)



## AL LIT RACK

Product #	Description	Size (inches)	Approx. weight (pounds)	Shipping Size	Ships ( ) Boxes
0-E277	The Alimalite Literature Rack is designed to mount to any standard Alimalite booth, and will hold 8.5" x 11" brochures/sell sheet.	13" x 4.25"	2	14" x 14" x 6"	(1)

*Your Design & Advertising agency... we are all about solutions!*



# ULTRAFORM COUNTERS



The UltraForm name is known industry-wide for consistent quality and the widest variety of cabinet and counter styles. **UltraLite:** A lightweight and economical of cabinets perfect for trade shows and events. Many have the same curve as a Pop-Up to nest against the backwall. Standard top colors black, white, or Amber Maple. All shown with optional graphics. (Available in your choice of 54 FRONTRUNNER™ or PRELUDE™ colors; all shown with optional graphics.)



Product #	Description	Case	Size (inches)	Approx. weight (pounds)	Shipping Size	Ships ( ) Boxes
ULCSK-36	UltraLite Computer Multi-cabinet, w/Keyboard Extension	UF4325	18 x 29 x 36	16	45 x 29 x 12	(1)



Product #	Description	Case	Size (inches)	Approx. weight (pounds)	Shipping Size	Ships ( ) Boxes
ULO2037-36	UltraLite Pedestal Oval Cabinet 36 (h)	UF4325	20 x 37 x 36	19	45 x 29 x 12	(1)
ULO2037-42	UltraLite Pedestal Oval Cabinet 42 (h)	UF4325	20 x 37 x 42	20	45 x 29 x 12	(1)



Product #	Description	Case	Size (inches)	Approx. weight (pounds)	Shipping Size	Ships ( ) Boxes
ULMK-36	UltraLite Computer Multi-cabinet, Kidney Shape	UF4325	18 x 29 x 36	16	45 x 29 x 12	(1)



Product #	Description	Case	Size (inches)	Approx. weight (pounds)	Shipping Size	Ships ( ) Boxes
ULKY105R	UltraLite Multi-Cabinet With Right Extension	UF4325	18 x 48 x 36	30	45 x 29 x 12	(1)
ULKY105L	UltraLite Pedestal Oval Cabinet 42 (h)	UF4325	18 x 48 x 42	30	45 x 29 x 12	(1)



Product #	Description	Case	Size (inches)	Approx. weight (pounds)	Shipping Size	Ships ( ) Boxes
ULOC1677-36	UltraLite Double Oval Curving Cabinet Set 36 (h)	UF4325	16 x 77 x 36	37	45 x 29 x 12	(1)
ULOC1677-42	UltraLite Double Oval Curving Cabinet Set 42 (h)	UF4325	16 x 77 x 42	40	45 x 29 x 12	(1)



Product #	Description	Case	Size (inches)	Approx. weight (pounds)	Shipping Size	Ships ( ) Boxes
ULKY-110	UltraLite Multi-Cabinet with connecting cabinet	UF4325	18 x 70 x 36	45	45 x 29 x 12	(1)

# ULTRAFORM COUNTERS



The UltraForm name is known industry-wide for consistent quality and the widest variety of cabinet and counter styles. **UltraLite:** A lightweight and economical of cabinets perfect for trade shows and events. Many have the same curve as a Pop-Up to nest against the backwall. Standard top colors black, white, or Amber Maple. All shown with optional graphics. (Available in your choice of 54 FRONTRUNNER™ or PRELUDE™ colors; all shown with optional graphics.)



Product #	Description	Case	Size (inches)	Approx. weight (pounds)	Shipping Size	Ships ( ) Boxes
MB2232-29	Tradition Rectangular Multi-stand 29 (h)	UF4325	22 x 32 x 29	32	45 x 29 x 12	(1)
MB2232-33	Tradition Rectangular Multi-stand 33 (h)	UF4325	22 x 32 x 33	38	45 x 29 x 12	(1)
MB2232-42	Tradition Rectangular Multi-stand 42 (h)	UF4325	22 x 32 x 42	40	45 x 29 x 12	(1)



Product #	Description	Case	Size (inches)	Approx. weight (pounds)	Shipping Size	Ships ( ) Boxes
OMB2043-29	Tradition Oval Multi-stand 29 (h)	UF4825	20 x 43 x 29	34	51 x 29 x 12	(1)
OMB2043	Tradition Oval Multi-stand 33 (h)	UF4825	20 x 43 x 33	34	51 x 29 x 12	(1)
OMB2043	Tradition Oval Multi-stand 42 (h)	UF4825	20 x 43 x 42	34	51 x 29 x 12	(1)



Product #	Description	Case	Size (inches)	Approx. weight (pounds)	Shipping Size	Ships ( ) Boxes
ULFC2132-36	Peddler II Demo Cabinet 36 (h)	UF4325	21 x 32 x 36	19	51 x 29 x 12	(1)
ULFC2132-42	Peddler II Demo Cabinet 42 (h)	UF4325	21 x 32 x 42	21	51 x 29 x 12	(1)
ULFC2132-36	Peddler banner kit	UF4325	21 x 32 x 36	19	51 x 29 x 12	(0)



Product #	Description	Case	Size (inches)	Approx. weight (pounds)	Shipping Size	Ships ( ) Boxes
HY105R	Tradition Bi-level Oval Multi-stand w/ right extension	UF4825	20 x 43 x 42	66	51 x 29 x 12	(1)
HY105L	Tradition Bi-level Oval Multi-stand w/ left extension	UF4825	20 x 43 x 42	66	51 x 29 x 12	(1)



Product #	Description	Case	Size (inches)	Approx. weight (pounds)	Shipping Size	Ships ( ) Boxes
CA323	Round Cabinet 23 diameter w/ two crescents	UF4325	42 , 33 and 24 h	59	45 x 29 x 12	(1)



Product #	Description	Case	Size (inches)	Approx. weight (pounds)	Shipping Size	Ships ( ) Boxes
CTR46-29	Tradition Pedestal Round w/ split top 29 (h)	UF4831	46 x 29	45	51 x 34 x 12	(1)
CTR46-42	Tradition Pedestal Round w/ split top 42 (h)	UF4831	51 x 42	51	51 x 34 x 12	(1)

*Your Design & Advertising agency... we are all about solutions!*



# ROTOMOLDED CASES

We offer a wide variety of lightweight, wheeled, trade show display and graphics shipping cases. Our cases are manufactured in the USA using recycled icorene resin for strength and most ship FedEx or UPS.

## MULTICONNECT / LAMINATE / PANEL SYSTEM / ALUMALITE / ULTRAFORM CASES



**UF4831**

(exterior: 50"H x 34"W x 10"-14"D)  
(interior: 48"H x 31"W x 6"-10"D)  
WEIGHT: 40 lbs.



**UF4825**

(exterior: 50"H x 27"W x 10"-16"D)  
(interior: 48"H x 25"W x 7"-13"D)  
WEIGHT: 35 lbs.



**UF4325**

(exterior: 44"H x 27"W x 10"-16"D)  
(interior: 43"H x 25"W x 7"-13"D)  
WEIGHT: 34 lbs.



**UF4848**

(exterior: 33.5"H x 51.5"W x 51.5"D)  
(interior: 28.5"H x 48"W x 48"D)  
WEIGHT: 103 lbs.



**TOP LOADING CASE  
5PCC-02**

(exterior: 48"H x 28"W x 9"-13"D)  
(interior: 47"H x 24"W x 8"-12"D)  
WEIGHT: 26 lbs.



**TOP LOADING CASE  
5PCC-05**

(exterior: 52"H x 26.5"W x 11.5"D)  
(interior: 49.25"H x 24"W x 9.5"D)  
WEIGHT: 26 lbs.



**TRANSPORT TUB  
5TUB**

(exterior: 55"H x 40.5"W x 29.5"D)  
(interior: 47.25"H x 35"W x 23.75"D)  
WEIGHT: 153 lbs.

## POP-UP CASES



**CYLINDRICAL 4106**

(exterior: 35"H x 16"W x 17"D)  
WEIGHT: 30 lbs.



**4100**

(exterior: 38.125"H x 13.75"W x 19.25"D)  
WEIGHT: 15.5 lbs.

## ROTOMOLDED CASES

We offer a wide variety of lightweight, wheeled, trade show display and graphics shipping cases. Our cases are manufactured in the USA using recycled icorene resin for strength and most ship FedEx or UPS.

### POP-UP CASES



**OVAL 4400**

(exterior: 38"H x 27.5"W x 16"D)  
(interior: 36"H x 24"W x 14"D)  
WEIGHT: 24 lbs.



**ALL-IN-ONE 4600**

(exterior: 37.5"H x 26.5"W x 18"D)  
(interior: 35"H x 23.75"W x 7"-15"D)  
WEIGHT: 23 lbs.



**INTERLOCKING 4200 A/B**

exterior: A. (39.5"H x 20"W x 14.25"D) B. (39.5"H x 20"W x 18"D)  
Interior: A. (34"H x 18"W x 9.5"D) B. (36"H x 18"W x 15.5"D)  
A. WEIGHT: 26 lbs. / B. WEIGHT: 24 lbs.

### GRAPHICS CASES



**4150**

(exterior: 29.5"H x 20"W x 16"D)  
(interior: 26"H x 12"W x 12"D)  
WEIGHT: 12 lbs.



**4156**

(exterior: 35.5"H x 20"W x 16"D)  
(interior: 31"H x 12"W x 12"D)  
WEIGHT: 13 lbs.



**4151**

(exterior: 41.5"H x 20"W x 16"D)  
(interior: 38"H x 12"W x 12"D)  
WEIGHT: 15 lbs.



**4154**

(exterior: 45.5"H x 23"W x 20"D)  
(interior: 42"H x 16"W x 16"D)  
WEIGHT: 24 lbs.



**4152**

(exterior: 53.5"H x 20"W x 16"D)  
(interior: 50"H x 12"W x 12"D)  
WEIGHT: 16 lbs.



**4155**

(exterior: 53.5"H x 23"W x 20"D)  
(interior: 50"H x 16"W x 16"D)  
WEIGHT: 25 lbs.



**4153**

(exterior: 75.5"H x 20"W x 16"D)  
(interior: 72"H x 12"W x 12"D)  
WEIGHT: 25 lbs.

*Your Design & Advertising agency... we are all about solutions!*

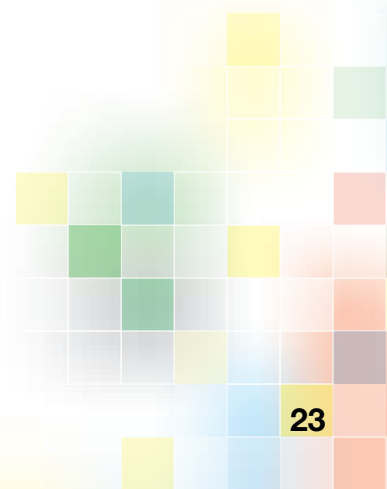



# INTERLOCKING TRADE SHOW CARPET

Modular Carpet that sets up in minutes! Anti-Fatigue - Resists cuts. (UPS shippable)



## COMFORT CARPET PLUS

### 5/8 Plush Interlocking Flooring

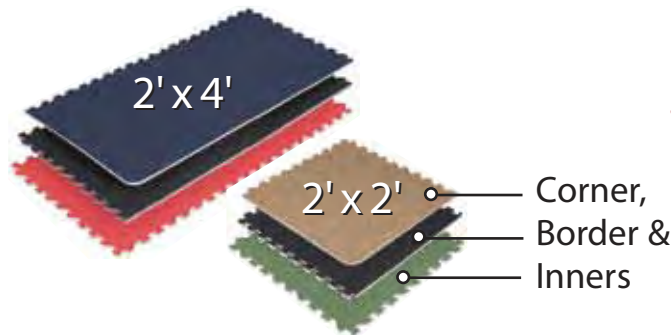
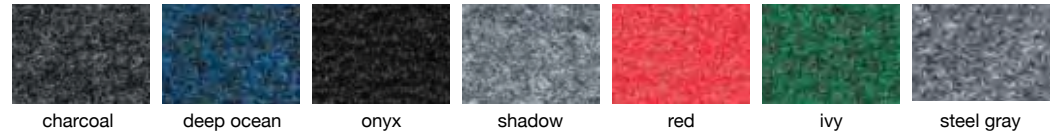

## COMFORT CARPET PLUS

Extra plush, premium-quality, padded, interlocking trade show carpeting.

Item #	Description	Tile Size	Approx. weight (pounds)	Shipping Size	Ships (boxes)
KS-C1010B	10 x 10 base package	2 x 2	75	50 x 25 x 11	(1)
KS-C1010BE	10 x 10 base package with beveled edging	2 x 2	75	50 x 25 x 11	(1)
KS-C1010BC	10 x 10 base package with electric cord channeling	2 x 2	75	50 x 25 x 11	(1)
KS-C1010BCE	10 x 10 base package with electric cord channeling and beveled edging	2 x 2	75	50 x 25 x 11	(1)
KS-C1020B	10 x 20 base package	2 x 4	135	25 x 25 x 32	(1)
KS-C1020BE	10 x 20 base package with beveled edging	2 x 4	135	25 x 25 x 32	(1)
KS-C1020BC	10 x 20 base package with electric cord channeling	2 x 4	135	25 x 25 x 32	(1)
KS-C1020BCE	10 x 20 base package with electric cord channeling and beveled edging	2 x 4	135	25 x 25 x 32	(1)
KS-SCM1010	Molded Plastic case for 10x10 package	2 x 4	75	50 x 25 x 11	(1)
KS-SCS1010	Soft fabric case for 10x10 package	2 x 4	50	50 x 30 x 10	(1)
KS-SCH1020	Hard shipping case for 10x20 package	2 x 4	132	25 x 25 x 32	(1)





# SIERRA COLLECTION™ HARDWOOD FLOORING.

Interlocking 39 x 39 Squares



Maple



Red oak



Ash



Beech



Oak Granada



Oak Lexington

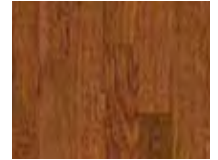

Oak Nashville



Oak San Jose



Oak San Antonio

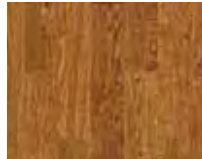

Oak Monte Carlo



Red Oak Monte Carlo



Red Oak New York



Oak Mocha



Oak Salem

## HARDWOOD INTERLOCKING FLOORING - SIERRA COLLECTION

Sierra Collection hardwood trade show flooring comes in 39" x 39" interlocking squares that assemble easily - no tools necessary. Each panel weighs 26lbs and features a durable polyurethane satin finish. Each flooring package includes edging and wood shipping crate.

Item #	Description	Tile Size	Approx. weight (pounds)	Shipping Size	Ships (boxes)
KS-H1010	10 x 10 Hardwood flooring package	39 x 39	310	40 x 40 x 27.5	(1)
KS-H1020	10 x 20 Hardwood flooring package	39 x 39	505	40 x 40 x 27.5	(1)



*Your Design & Advertising agency... we are all about solutions!*

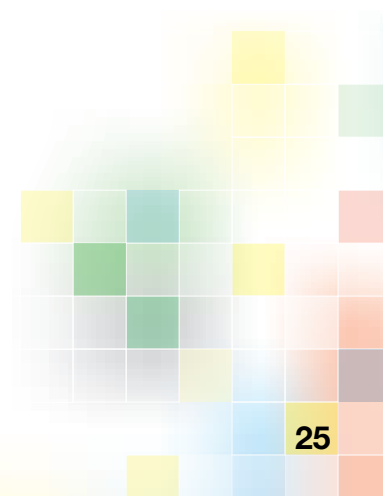



# FABRIC COLORS

We offer the following 53 FRONTRUNNER™ or PRELUDE™ fabric color options for Pop-up displays, Case-to-table conversion kits, UltraForm counters and Multiconnect panel systems. Use the color names below when placing your order. Same or next day shipping on pop-ups is available for Imperial, Silver and Coal fabric colors only. All orders for same day shipping must be placed before 10:00 AM PST.



# STANDARD LAMINATE COLORS

Choose from the following 12 standard laminates for panel system, and hundreds of custom laminate colors available which may incur an upcharge and extend lead time.



# BANNERSTANDS



## EZ Up 123™ Telescoping Roll-Up Banner Stand

**The ultimate, low-cost solution for “anywhere” display graphics!**

The EZ UP 123™ Banner Display System supports a variety of digital and screen printed graphics and comes complete with a nylon case, support pole, attached legs and an unwind case (graphics sold separately). Made from high-quality aluminum extrusion, the EZ UP 123 provides a quality banner display at a very affordable price!

Product #	Size (inches)	Approx. weight	Shipping Size	Ships ( ) Boxes
S-EU30T	31 x 32 to 85 (80 height recommended)	16	48 x 12 x 5	(1)
S-EU42T	42 X 32 to 85 (80 height recommended)	12.1	49 x 12 x 5	(1)



## EZ Up 123™ Double Roll-Up Banner Stand

**Double your exposure! Low-cost, two-sided banner displays**

Double-sided, roll-up banner stand with streamlined design. Single wire leg provides stable base. Fixed pole height for consistent presentation. Includes convenient case for easy transport.

Product #	Size (inches)	Approx. weight (pounds)	Shipping Size	Ships ( ) Boxes
S-EU30DS	30 x 78	15	36 x 12 x 5	(1)
S-EU42DS	39 x 78	17	45 x 12 x 5	(1)

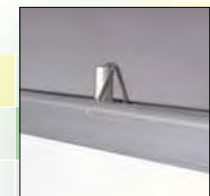

*Your Design & Advertising agency... we are all about solutions!*



# BANNERSTANDS

## Deluxe Roll-Up Banner Stand



**Enhance your banner with this attractive, deluxe roll-up banner stand!**

The deluxe roll-up banner stand features a clip-style top rail for easy installation of graphics - no adhesive required! The attractive chrome base design enhances the presentation of the installed banner.

Product #	Size (inches)	Approx. weight	Shipping Size	Ships ( ) Boxes
S-EULD31	31 x 78.5	16	38 x 12 x 5	(1)
S-EULD43	42 X 78.5	12.1	49 x 12 x 5	(1)



## Heavy Duty Banner Stand



**Heavy-weight base with adjustable supports**

The heavy duty banner stand features a clip-style top rail for easy installation of graphics - no adhesive required! The legs can be adjusted to the front or back to provide added stability.

Product #	Size (inches)	Approx. weight (pounds)	Shipping Size	Ships ( ) Boxes
S-EUFL31	31 x 80	15	36 x 12 x 5	(1)
S-EUFL43	43 x 80	17	45 x 12 x 5	(1)



# BANNERSTANDS

## Compact Scrolling Banner Stand

**Put your message in motion with a scrolling banner stand!**

Double the amount of information you display with our chrome scrolling banner stand! The banner continuously scrolls, drawing more attention to itself and displaying more information.



Product #	Size (inches)	Approx. weight (pounds)	Shipping Size	Ships ( ) Boxes
S-EUSC31	30.5 x 80 (159.9 banner length)	16	38 x 12 x 5	(1)



## Wide Base Scrolling Banner Stand

**Wide base scrolling banner stand adds greater stability!**

Double the amount of information you display with our wide base scrolling banner stand! The wider base adds greater stability for high traffic locations.



Product #	Size (inches)	Approx. weight (pounds)	Shipping Size	Ships ( ) Boxes
S-EUSK31	31 x 81 (163 banner length)	15	38 x 16 x 8	(1)



## Hanging Scrolling Banner Display

**Put your message in motion with a high impact, hanging banner!** (Ceiling clips and hanging wire sold separately)

Our scrolling, hanging banner display continuously scrolls, drawing more attention. The hanging design of the display allows for variable height banners, and is ideal for retail applications where floor space is at a premium.



Product #	Size (inches)	Approx. weight (pounds)	Shipping Size	Ships ( ) Boxes
S-EUSH31	31 x up to 60	15	36 x 12 x 5	(1)

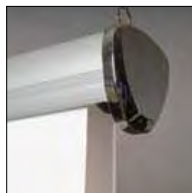

*Your Design & Advertising agency... we are all about solutions!*



# BANNERSTANDS

## 4-Leg Banner Stand



### **Quick set-up, variable eight banner stand!**

This 4-leg stand features top and bottom rails with pre-applied adhesive for quick and easy mounting of graphics. The adjustable attachment clips accommodate variable height banners.

Product #	Size (inches)	Approx. weight	Shipping Size	Ships ( ) Boxes
S-EU4L23	23 x 74	16	28 x 12 x 5	(1)
S-EU4L31	31 X 74	12.1	49 x 12 x 5	(1)

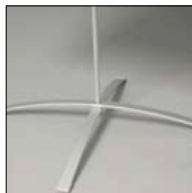

## Platform Base Banner Stand

### **Banner stand with weighted base for added stability!**

This lightweight stand features adjustable attachment clips that accommodate variable height banners. The attractive chrome base provides added stability.



Product #	Size (inches)	Approx. weight (pounds)	Shipping Size	Ships ( ) Boxes
S-EUPB23	23 x 73	15	29 x 12 x 5	(1)
S-EUPB31	31 x 73	17	45 x 12 x 5	(1)



# BANNERSTANDS



## L Banner Stand B

**Free-standing banner stand with easlily inserted graphics!**

The "L" style banner stand features a clip-style top and bottom rail for easy insertion of graphics. The tension fit pole creates a nice presentation of the graphic.

Product #	Size (inches)	Approx. weight (pounds)	Shipping Size	Ships ( ) Boxes
S-EULB20	20 x 85	16	28 x 12 x 5	(1)
S-EULB30	30 X 85	12.1	38 x 12 x 5	(1)
S-EULB40	40 X 85	12.1	49 x 12 x 5	(1)

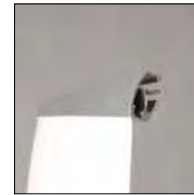

## L Banner Stand C

**Free-satnding banner stand with heavy duty base!**

The "L" style banner stand "C" features a heavier base support for added stability. It has a clip-style top and bottom rail for easy insertion of graphics. The tension fit pole creates a nice presentation of the graphic.

Product #	Size (inches)	Approx. weight (pounds)	Shipping Size	Ships ( ) Boxes
S-EULC20	20 x 85	15	28 x 12 x 5	(1)
S-EULC30	30 x 85	17	38 x 12 x 5	(1)
S-EULC40	40 x 85	17	45 x 12 x 5	(1)

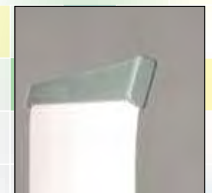
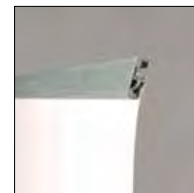

*Your Design & Advertising agency... we are all about solutions!*



# PROMOTOR



## PROMOTOR DEMO CENTER

is a round fronted lightweight portable demonstration promotional and in-store sampling counter designed for easy transportation. This re-useable easy to assemble display counter is available in Black or White. Polypropylene is the material used for the body panel incorporating unique hinges for easy folding. Vacuum formed super high impact polystyrene tops, bases, Forex headers, powder epoxy coated steel poles complete the product. One piece graphics and company logos can be produced for the front and sides of the body unit and the header. The Demo Centre comes complete with body panel, "rigidtop", base, poles, header and an over the shoulder zipped black nylon carry bag. Corporate Demo Center's when required in large quantities can be produced in special colours. Graphics and logos are screen printed directly onto the body panel and header using Sericol Polydyne inks.

Product #	Size (inches)	Approx. weight (pounds)	Shipping Size	Ships ( ) Boxes
PDC-N001	See opposite page	20	3.03 x2.77 x.27	(1)





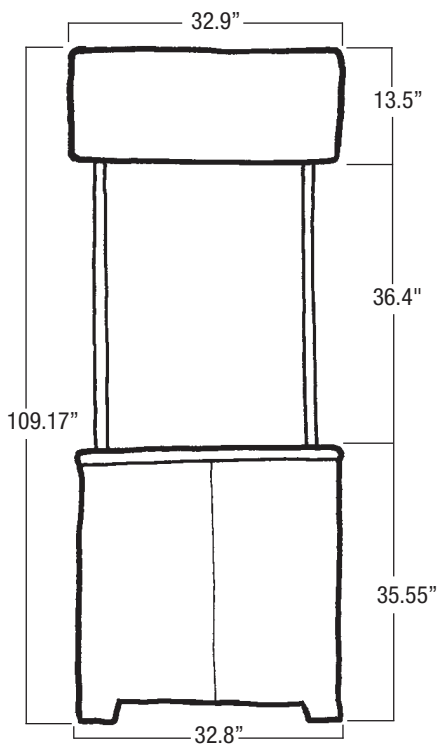

UNIT AND HEADER

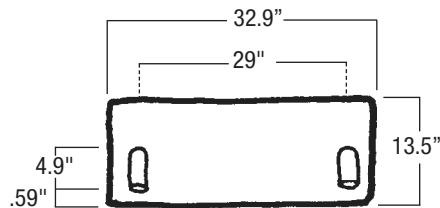

HEADER

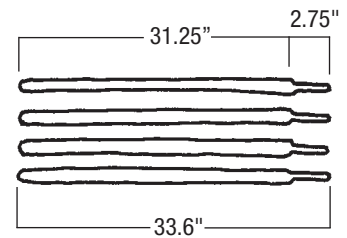

POLES

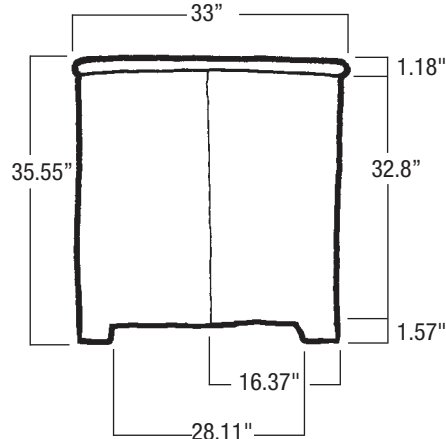

FRONT

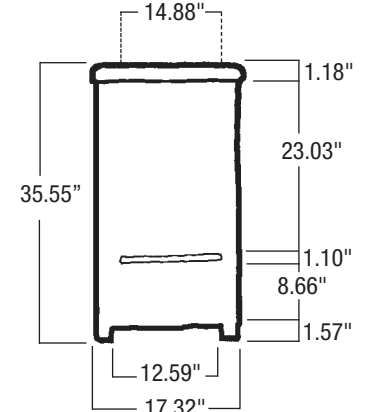

SIDE

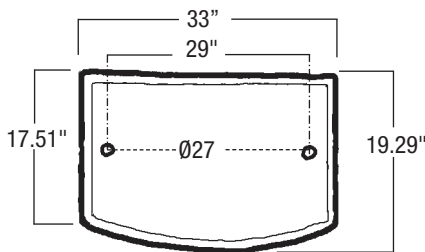

TOP

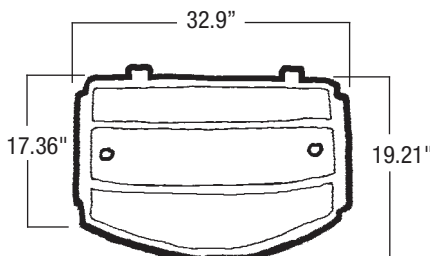

SHELF

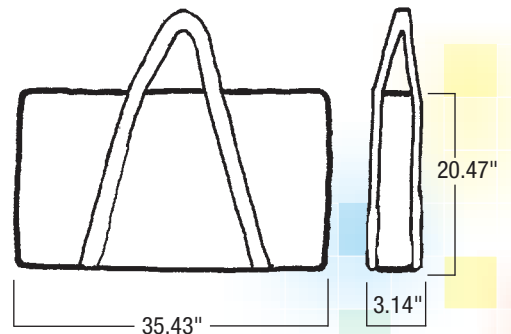

BAG

*Your Design & Advertising agency... we are all about solutions!*



**We are all about solutions!**

We will meet and work with you on the best marketing approach to help promote your brand. From the first concept to the day of the show and everything in between, we provide you with a complete service including graphic design, hardware, large format graphics and a knowledgeable staff to guide you through the process. Every job gets personalized attention because no job is too small.

• parade floats and inflatables



• promotional merchandise



lighters



calendars



matches



drink coolers

• wearables & gifts



wearables



hats



gifts



coffee mugs

## Brand & Package Design | Corporate ID & Communications Design | Web Design

For over 15 years, NEMA has carved a remarkable niche in several industries including food label design, corporate presentation, and concept development. Our unique set of capabilities will allow us to serve your company's marketing needs.

Call for a free consultation. You have everything to gain in your marketing efforts.

### • graphic design



package design



corporate id



web design



advertising

### • store decorations



custom backlit signs



light boxes



store decoration



floor decal

### • event support



table covers



event entertainment



event wearables



glassware

*Your Design & Advertising agency... we are all about solutions!*

# Winning presentations!

